

# HIGH FREQUENCY STATE-VARIABLE BIQUADRATIC ACTIVE FILTERS

Tomáš DOSTÁL,  
Institute of Radioelectronics,  
Technical University of Brno  
Purkyňova 118, 612 00 BRNO,  
Czech Republic

## Abstract

The state-variable (KHN) active RC biquadratic filters with good performance in high frequency range, flexibility of outputs (LP, HP, BP), low sensitivities in novel current and hybrid modes, using current conveyors, transimpedance, trans-admittance and current operational amplifiers, are given in this paper.

## Keywords

analogue signal processing, voltage, current and hybrid modes, active RC filters, state-variable synthesis.

## 1. Introduction

The recent progress of the analogue technology allowed, that the semiconductor industry has launched a new breed of monolithic IC functional blocks (special operational amplifiers etc.), with some of the higher speeds, lager bandwidths greater than several hundred MHz and slew-rates of the order of 3000 V/ $\mu$ s.

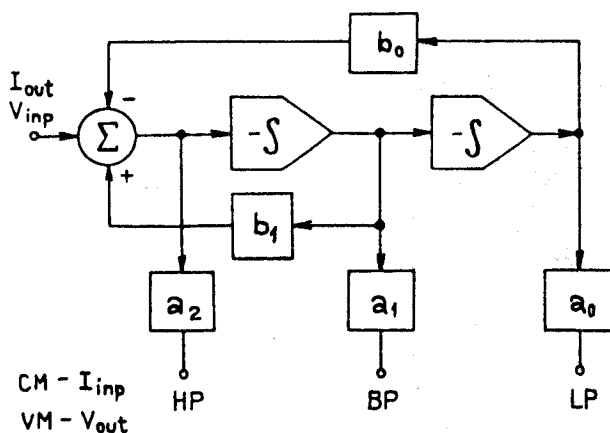

Fig.1 Block diagram of state-variable biquad

Such blocks are especially the current conveyors of first generation (CC I) and second generation (CC II), the transadmittance (transconductance) operational amplifiers (TAOA resp. OTA), the transimpedance (transresistance) operational amplifiers (TIOA), the current feedback operational amplifiers (CFOA) and the current operational amplifiers (COA). All these blocks have subsequently become as essential elements in the current mode of the analogue signal processing, what has made novel conceptions in simulation process and circuit design [2].

From principle of methodology, several operating modes in analogue signal processing can be defined, namely the classical voltage one (VM), the current mode (CM) [2] and two hybrid modes (HM), namely the voltage-current mode (V/CM) and the current-voltage mode (C/VM) respectively [3]. The CM technique appears [2] as a rival of the prominence against the conventional circuits in the VM, where the parasitic inherent features of the real operational amplifiers play more characteristic roles, specially in high frequency region. It is well known that the frequency range of the VM filters can be only ten times less than the GBP of the operational amplifiers. Furthermore a large signal slewing effect of the amplifier may restrict the operating bandwidth of the VM filters too. It was the reason, for what the CM has been developed. The adjoint transformation suggested in [2] can be used as straightforward method to obtain the CM filters from their VM counterparts. In this case, the current transfer functions of the resulting CM networks are identical to the voltage transfer functions of the VM prototypes. Furthermore, the sensitivities of the network functions are identical too. Using this way, the previously designed [1] state-variable (KHN) active RC biquadratic VM filter can be directly transformed into the CM modification, without losing its optimum characteristics.

## 2. State-variable biquad

The biquadratic transfer function, which has following general form

$$K(p) = \frac{a_2 p^2 + a_1 p + a_0}{b_2 p^2 + b_1 p + b_0} = K_0 \frac{p^2 + \frac{\omega_n}{Q_n} p + \omega_n^2}{p^2 + \frac{\omega_p}{Q_p} p + \omega_p^2}, \quad (1)$$

can be implemented by two integrators, using the state-variable method [1]. The block diagram is shown in Fig. 1.

There are one adder, five multipliers and two active integrators in the loop.

The general and ideal biquad of Fig.1 has been designed to implement the Butterworth LP, HP and BP filter with following specification:

$$f_p = 50 \text{ kHz and } Q_p = 0.707.$$

Then this circuit was simulated by software PSpice, to obtain the magnitude frequency responses for all outputs in ideal form of Fig. 2.

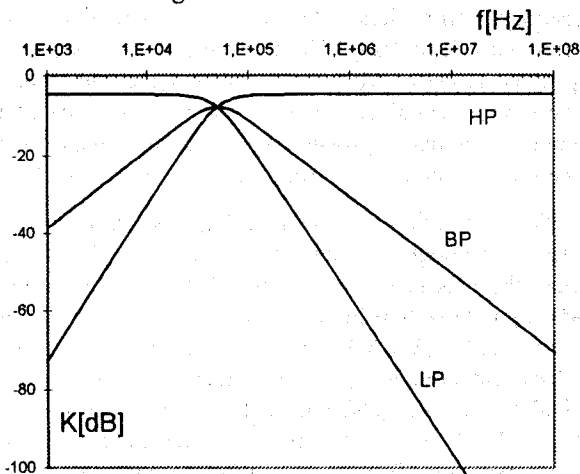

Fig.2 Magnitude responses of the KHN biquad in ideal case

### 3. KHN biquad in voltage mode

A particular VM version of the block diagram (Fig. 1) is well known KHN active RC filter (Fig. 3), proposed in [1], using three standard operational amplifiers. There is a flexibility of outputs, namely the types LP, HP or BP can be directly and simultaneously obtained. Elliptic or notch filter can be easily made by the other adder. Take note of very low sensitivities of this circuit [1].

#### KHN-VM

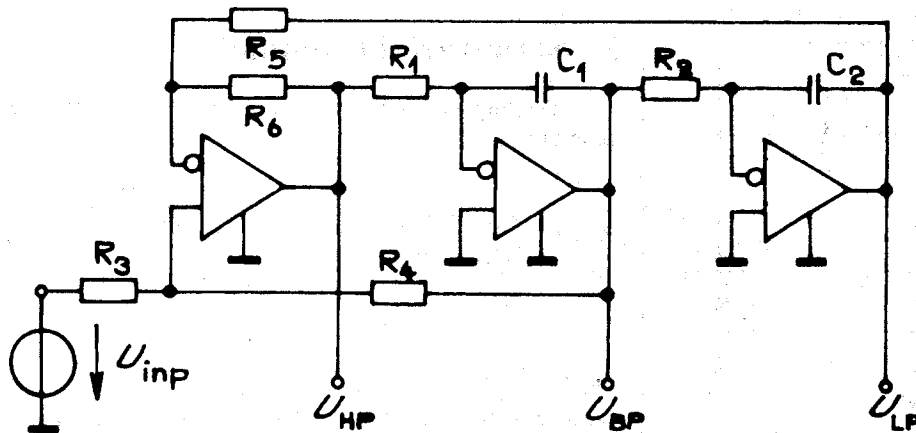

Fig. 3 KHN biquad in classical voltage mode

On the other hand, the parasitic inherent features of the real opamps (2) play here higher role, given by

$$A(p) = \frac{A_0 \omega_0}{1 + p} \quad (2)$$

The KHN-VM filter (Fig. 3), with the specification above, has been designed using synthesis from [1]. The real KHN-VM circuit, with the opamps LM 741, was simulated by PSpice, using professional model in detail. The obtained frequency magnitude responses are shown in Fig. 4. There is a very great distortion in high frequency region, comparing with ideal case Fig. 2. An additional phaseshift effects as a positive feedback and Q-factor has new higher value  $\bar{Q}$  given by (3) and the circuit can be unstable if the formula (4) is not valid

$$\bar{Q}^{-1} = \bar{d} = d - \frac{4\omega_p}{A_0 \omega_0} \quad (3)$$

$$\frac{4Q\omega_p}{A_0 \omega_0} \leq 0,1 \quad (4)$$

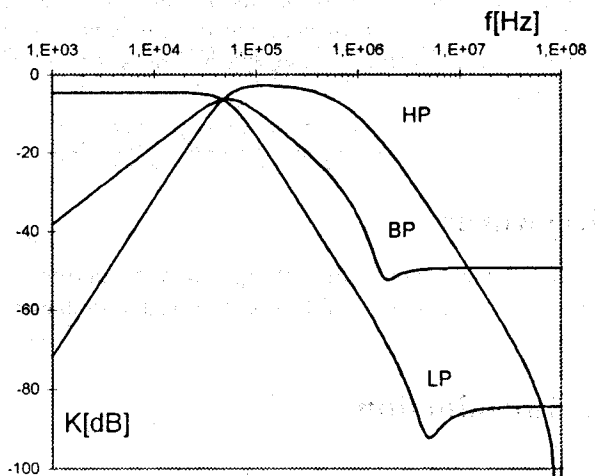

Fig.4 Magnitude responses of the KHN biquad in VM, using LM 741

Therefore the KHN-VM filter can be used either for lower Q only, or better type of the opamps, with higher  $\omega_0$ , must

be taken. It is reason, for the following CM and HM versions too.

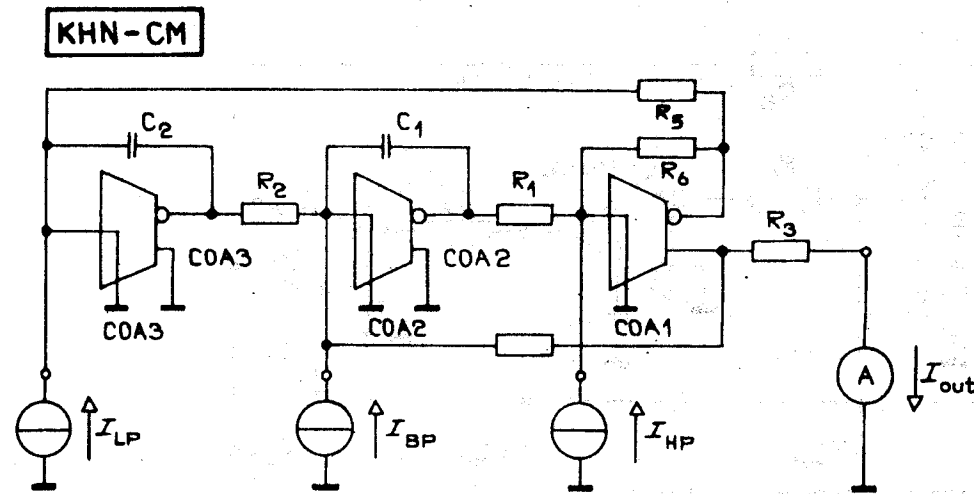

Fig. 5 KHN biquad in current mode using current amplifiers (SIDO-COA)

#### 4. KHN biquad in current mode

The block diagram of Fig. 1 is now converted to a corresponding reciprocal network in CM. This network can be created by the adjoint transformation from [2]:

- reversing the input and output ports.
- changing the voltage to the current excitation.
- using the current integrators from [4],
- changing the voltage adder by current divider.

The resulting circuit diagram of the practical KHN-CM filter, using the current operational amplifiers [4] (single input differential output) SIDO-COA, is shown in Fig. 5.

Here the current transfer function has the form of the eq. (1), with the following coefficients of the denominator.

$$b_0 = \frac{A_1 - 1}{C_1 C_2 R_1 R_2}, \quad (5)$$

$$b_1 = \frac{A_1(A_2 - 1)}{A_2 C_1 R_2}, \quad (6)$$

$$b_2 = 1, \quad (7)$$

where

$$A_1 = 1 + \frac{R_6}{R_5}, \quad (8)$$

$$A_2 = 1 + \frac{R_3}{R_4} \quad (9)$$

From these eq's the basic parameters of the KHN-CM filter can be easily derived, namely the frequency (10) and Q-factor (11) of the poles in the symbolic form

$$\omega_p = \sqrt{\frac{A_1 - 1}{C_1 C_2 R_1 R_2}}, \quad (10)$$

$$Q = \frac{A_2}{A_1(A_2 - 1)} \sqrt{(A_1 - 1) \frac{C_1 R_1}{C_2 R_2}} \quad (11)$$

The coefficients of the numerator are given as follows

- for the output LP:

$$a_0 = \frac{A_1}{A_2} C_1 C_2 R_1 R_2, \quad a_1 = a_2 = 0, \quad (12)$$

- for the output BP:

$$a_1 = -\frac{A_1}{A_2} C_1 R_1, \quad a_0 = a_2 = 0, \quad (13)$$

- for the output HP:

$$a_2 = \frac{A_1}{A_2}, \quad a_0 = a_1 = 0, \quad (14)$$

Using these eq's the KHN-CM filter from Fig. 5 has been designed, for the above specification, and than tested, using the PSpice. For the present tentative experiment, the COA's were modelling by current-controlled current sources only. The obtained frequency magnitude responses tend to the ideal case of Fig. 2. The models of the higher level will be available in future.

#### 5. KHN biquad in hybrid mode

A practical implementation of the KHN filter, using the TIOA's with compensation pin (Z), is given in Fig. 6. The commercially available TIOA is for instance the type AD 844.

**KHN-VM/CM**

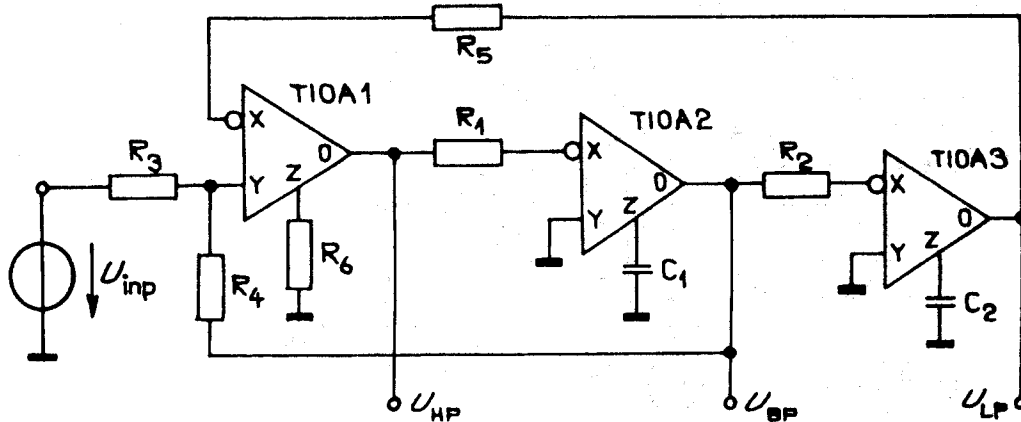

Fig. 6 KHN biquad in hybrid mode using transimpedance amplifiers (AD 844)

This KHN biquad in the HM (V/CM) was proposed from the VM block diagram (Fig. 1), where the VM integrators are implemented by the T10A's (they operate inside in the CM), with integrating capacitors on the port Z. The KHN-HM (Fig. 6) is described by the same eq's (5) to (14), as the KHN-CM (Fig. 5). To verify the theoretical results and experimentally compare the performance of this HM with the VM variant, the same filter has been design, with the specification given above. The real KHN-HM circuit was simulated by PSpice too, modelling the AD 844 in detail, by the professional model of high level. The obtained frequency magnitude responses are shown in Fig. 7. There (Fig. 7) the distortion is smaller, comparing with Fig. 4 of the VM.

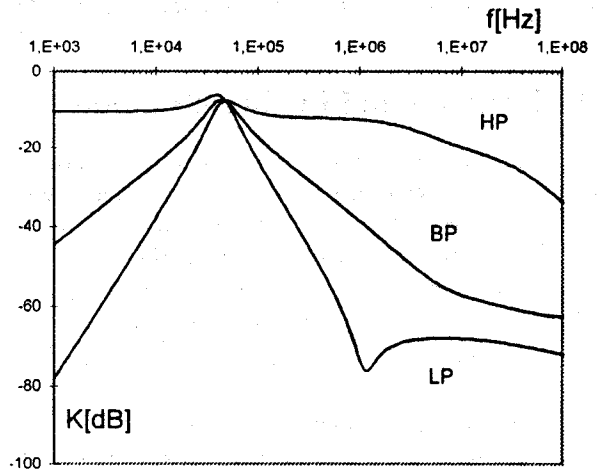

Fig. 7 Magnitude responses of the KHN biquad from Fig. 6, using transimpedance amplifiers AD 844

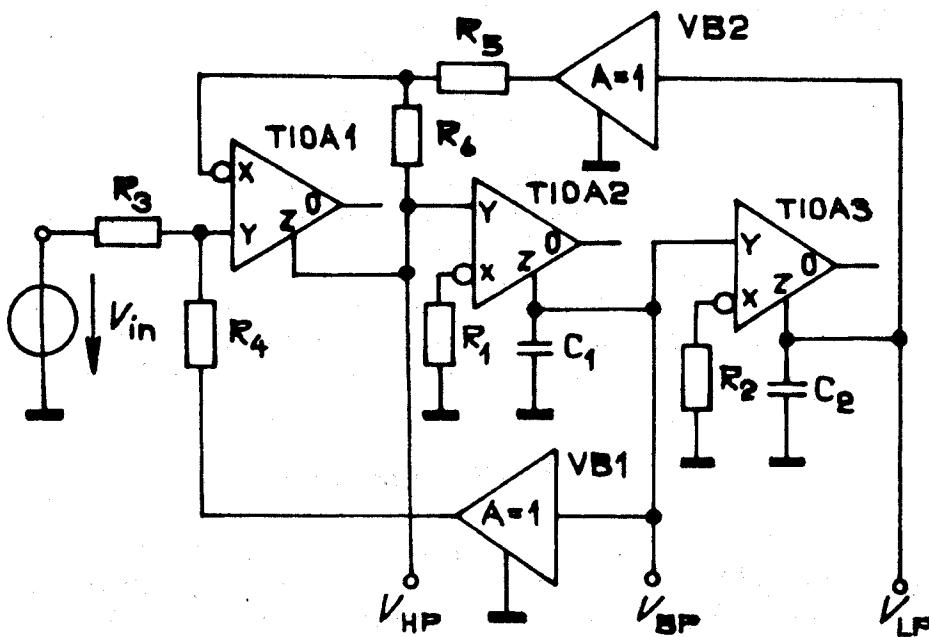

Fig. 8 KHN biquad using current conveyors as the part of AD 844

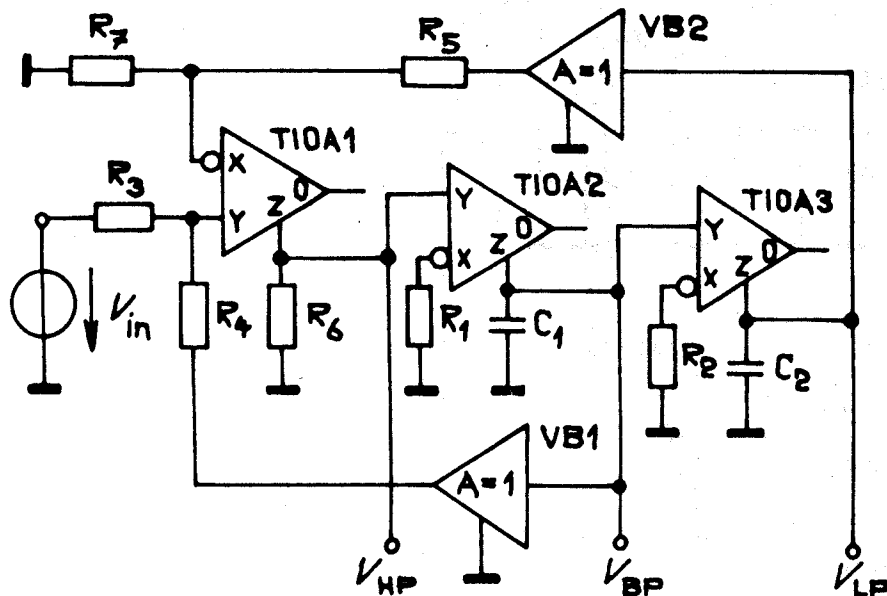

Fig. 9 Modification of the KHN biquad with current conveyors

## 6. KHN biquad using current conveyors

There the current conveyors CC II can be used in this KHN structure as well. Two interesting equivalent realisations were introduced in [5], the other will be given here. The approach is based on realising the basic building blocks of Fig. 1, namely integrators and adder, by the CC II and then connecting these blocks correctly. The realisation of the inverting voltage integrator using the CC II grounded R and C is well known [5]. Although the adder and integrators can be cascaded, the integrator outputs must be buffered before being connected to the proper adder inputs. There are two more CC II's used as voltage followers in [5].

The other ingenious modification is shown in Fig. 8. Here the inverting voltage integrators are implemented by the CC II's, as the first part of the above TIOA [2] (have a look at TIOA2 and TIOA3 grounded R and C). The TIOA1 operates as an adder (similarly the first part only, that is CC II too). For the voltage buffers (VB1 and VB2), the second part of AD 844 can be used. The modification of this circuit is shown in Fig. 9, using an idea of summer equivalents from [5] - replacing floating resistor  $R_6$  (Fig. 8), connected between ports X-Y, with two grounded resistors in Fig. 9 ( $R_6$  and  $R_7$ ), which have half value of resistances. This resulting circuit of Fig. 9 has been design with specification given above and then simulated by PSpice as above, to obtain the magnitude responses with smaller distortion (Fig. 10) comparing with the previous case (Fig. 7). One can see that this modification is the better choice for high frequency application.

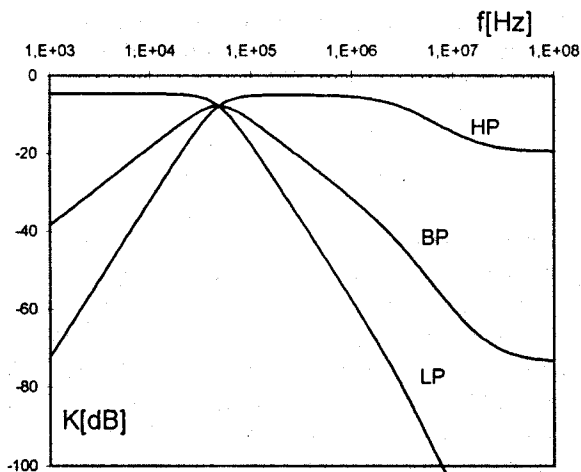

Fig. 10 Magnitude responses of the KHN biquad from Fig. 9, using current conveyors

## 7. KHN biquad using transadmittance operational amplifiers

Recently the other approach for the generation of two-integrator-loop filter structures using transadmittance (transconductance) operational amplifiers (TAOA or OTA) has been given [6]. The block diagram of Fig. 1 can be implemented by circuit realisation in Fig. 11. Here fifth differential-input single-output TAOAs and two grounded capacitors are used. Furthermore the grounded resistor R can be, in monolithic IC form, replaced by the other TAOA, as was shown in [6]. The voltage transfer function (1) has the coefficients of the denominator

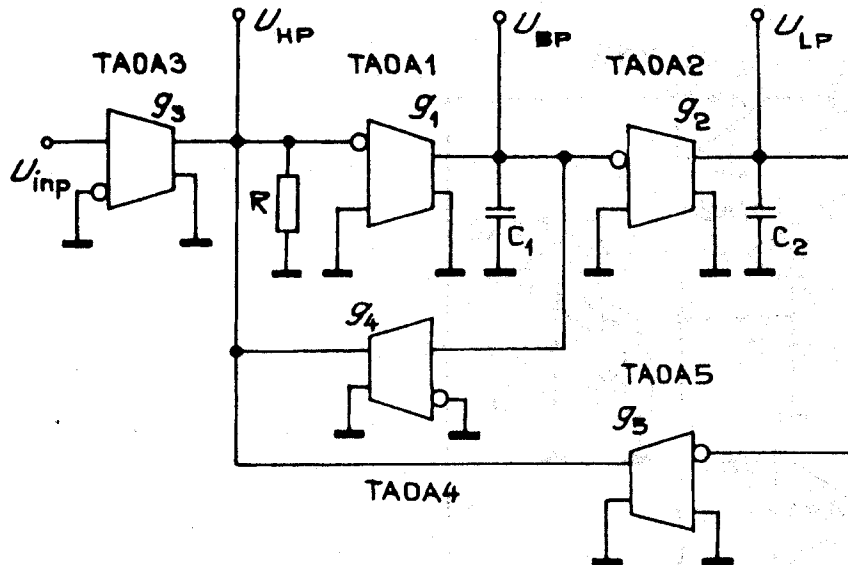

Fig. 11 KHN biquad using transimpedance amplifiers

$$b_2 = 1, \quad b_1 = \frac{Rg_1g_4}{C_1}, \quad b_0 = \frac{Rg_1g_2g_5}{C_1C_2}. \quad (15)$$

The coefficients of the numerator are given as follows

- for the output LP:
 
$$a_0 = \frac{Rg_1g_2g_3}{C_1C_2}, \quad a_1 = a_2 = 0, \quad (16)$$

- for the output BP:
 
$$a_1 = -\frac{Rg_1g_3}{C_1}, \quad a_0 = a_2 = 0, \quad (17)$$

- for the output HP:
 
$$a_2 = Rg_3, \quad a_1 = a_0 = 0. \quad (18)$$

Other different topologies using voltage or current integrators with TIOA will be given and study in [7].

## 8. Conclusion

The voltage, current and hybrid modes of the state-variable active RC biquadratic KHN filter have been given, compared and experimentally tested. In any case an important conclusion may be generally pointed out as follows. The hybrid (voltage-current) mode and specially full current one are closer to the ideal case. They can be used over a much wider bandwidth than the corresponding voltage mode. It is apparent that the commercially available transimpedance opamp, with compensation pin (AD 844 or AD846) is surely a right choice to implement high performance KHN biquad in the hybrid mode.

This work has been supported by the Grant Agency of Czech Republic, grant No. 102/0994/1996.

## References

- [1] KERVIN, W.J.-HUELSMAN, L.P.-NEWCOMB, R.W.: State-variable synthesis for insensitive integrated circuit transfer functions. IEEE-SC, 1967, Vol. 2, No. 2, pp. 87-92.
- [2] TOUMAZOU, C.-LIDGEY, F.J.-HAIGH, D.G.: Analogue IC design: The current-mode approach. Peter Peregrinus Ltd., London, 1990.
- [3] DOSTÁL, T.: Insensitive voltage-mode and current-mode filters from transimpedance opamps. IEE Proc.-G, Vol. 142, No. 2, Apr. 1995, pp. 140 - 144.
- [4] DOSTÁL, T.-ŠENK, L.: Integrators with current operational amplifiers. In: Proc. of „Radioelektronika' 96, FEI VUT, Brno, 1996, pp. 38 - 41.
- [5] SOLIMAN, A.M.: Kervin-Huelsman-Newcomb circuit using current conveyors. Electronics Letters, Vol. 30, No. 24, Nov. 1994, pp. 2019-2020.
- [6] SÁNCHEZ, S. E.-GEIGER, R.L.-NEVÁRES, L.H.: Generation of continuous-time two integrator loop OTA filter structures. IEEE Trans. Circuits Syst., Vol. 35, 1988, pp. 936 - 946.
- [7] DOSTÁL, T.: Integrators with transadmittance operational amplifiers. In: Proc. of „Radioelektronika' 98", FEI VUT, Brno, 1998, will be published.

## About authors...

**Tomáš DOSTÁL** was born in Brno, in 1943. He received the CSc. (Ph.D) and DrSc. degree in electrical engineering from the Technical University Brno in 1976 and 1989 respectively. From 1973 to 1978, and from 1980 to 1984, was with Military Academy Brno, from 1978 to 1980 with Military Technical College Baghdad. Since 1984 he has been with the Technical University Brno, where he is now Professor of Radioelectronics. His present interests are in the circuit theory, filters, switched capacitor networks and circuits in current mode.